

# LINK COMMUNICATIONS BCD INTERFACE

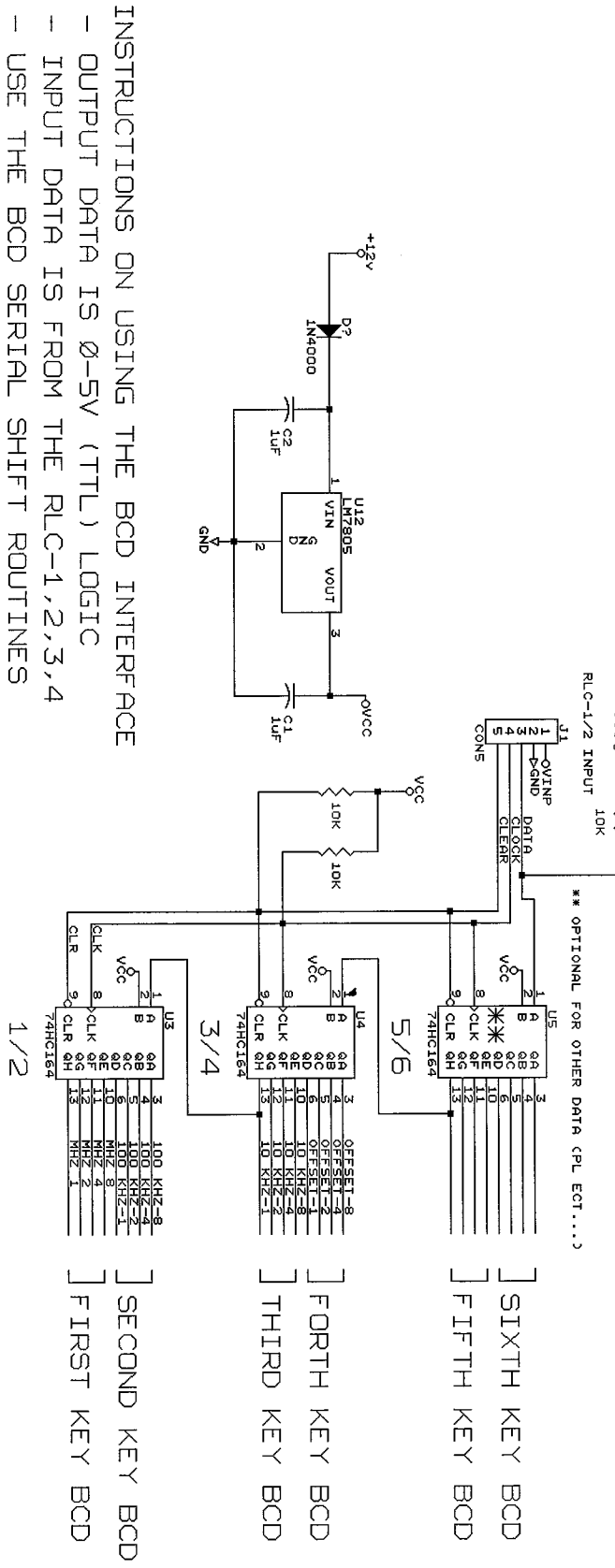

- INSTRUCTIONS ON USING THE BCD INTERFACE
- OUTPUT DATA IS 0-5V (TTL) LOGIC
  - INPUT DATA IS FROM THE RLC-1,2,3,4
  - USE THE BCD SERIAL SHIFT ROUTINES
  - THIS EXAMPLE USES 6 DIGITS OF DATA
  - LESS DIGITS USE LESS LATCHES
  - 5/6 LATCH IS ONLY NEEDED IF SHIFTING MORE THAN FREQ. DATA
  - (1/2), (3/4), (5,6) ARE THE KEYSTROKES USED
  - GOOD LUCK, CONTACT LINK COMMUNICATIONS INC. WITH QUESTIONS